

PE-HD Inspection and Flushing Chamber in Pickaback Arrangement for Traffic Route Engineering



MULTI-*inspect* 600 DUO

- Combined connection of carrier pipes and drainage pipes in pickaback arrangement
- Monolithic chamber basic body, body internal dimension > 600mm, ideal in cramped confines
- Size range: DN150 to DN400
- Full-length even-level flow channel
- Ideal for use in small laying depths
- Chamber riser pipe DU600
- Easy access to pipeline for inspection and flushing
- Suitable for SLW 60 classified roads

Complying with all requirements in road construction

HEGLER

Corrugated and Twin Wall Pipes of Plastics



Inspection and Flushing Chamber MULTI-*inspect* 600 DUO

MULTI-*inspect* 600 DUO system setup

The MULTI-*inspect* 600 DUO inspection and flushing chamber is made from PE-HD in one piece (monolithic basic body). With the excellent impact resistance of PE-HD, rupture and cracks in the chamber are prevented, even at low temperatures down to -25 °C. The MULTI-*inspect* 600 DUO chamber is designed as pickaback solution for connection of a carrier pipe at the bottom and a drainage pipe located above.

MULTI-*inspect* 600 DUO is available as straight-way chamber (180°) with a full-length even-level flow channel and in special designs.

Connection of pipe systems

The basic body features integral socket ends on both sides for a carrier pipeline in the size range up to DN400. By means of the available reducing connectors pipes of smaller sizes (DN150 to DN350) can be connected as well. The drainage pipe of DN150 is joined directly. The special way of interlocking between the reducing connectors and the basic body ensures tensile and twist-proof joining with the connected pipe systems. Assembly errors are excluded! A full-length even-level flow channel is guaranteed with all pipe sizes.

Chamber accessory

The riser pipe (extension) can be shortened, or elongated by extension pieces, to any length required. The chamber matches customary chamber covers, closed or gratings, of classes A 15, B 125 and D 400 to EN 124. Irrespective of the length of the riser pipe, loads up to traffic load class SLW 60 are distributed via a top concrete ring of 625mm to the bearing layer. The settlement cams provided in the coupler accommodating the riser pipe provide additional security in preventing damages to the basic body, should excessive forces occur during the building phase. The riser pipe is fitted with an SR end piece ensuring professional transition to the applied cover/concrete ring.

SYSTEM ADVANTAGES

- Pickaback arrangement with 15cm clearance between pipelines
- Body internal dimension > 600mm
- Slender design, ideal in cramped confines
- Full-length even-level flow channel
- Tensile interlock of reducing connectors (patent-protected)
- For a size range of 150mm to 400mm pipes
- Suitable for SLW 60 classified roads
- Low weight
- High impact resistance (PE-HD)
- Resistance to chemicals to DIN 8075
- Customary chamber covers to EN 124 (625mm)



MULTI-*inspect* 600 DUO

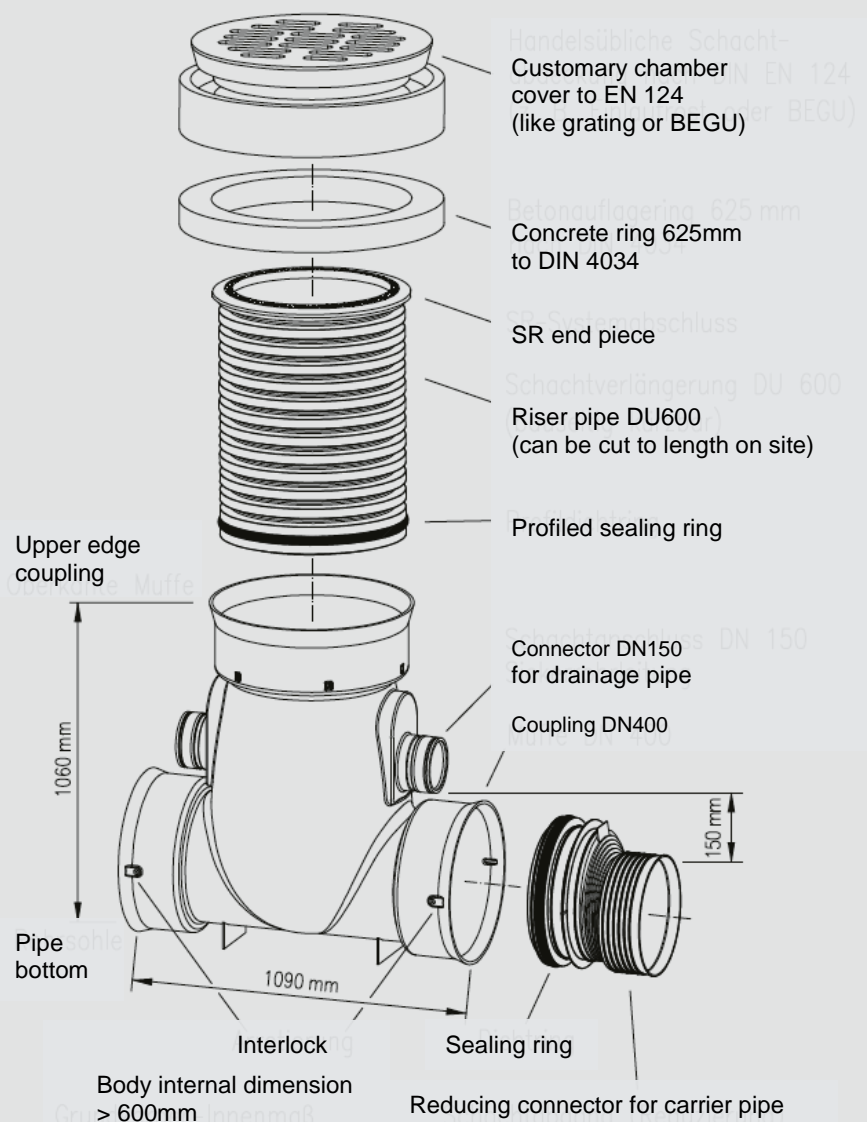

for Drainage and Carrier Pipe Lines in Pickaback Arrangement



Use in traffic route engineering

In order to avoid damages to the road construction in the long run, it is necessary to collect and professionally discharge any seepage water occurring in the road body and its border areas in addition to discharging the surface water via the carrier pipeline.

Thanks to its slender design the MULTI-*inspect* 600 DUO chamber is ideal for use in cramped confines. The pickaback arrangement permits full compliance with the requirements for base grade drainage and water discharge.

For this, the arrangement of the pipes in a pickaback layout is an optimum solution from the practical and cost-efficient point of view. With the HEGLER MULTI-*inspect* 600 DUO chamber the standard distance between the top pipe, i.e. the 150mm drainage pipe SIROPLAST-K, and the carrier pipeline AQUATUB-Rw is 15cm. The riser pipe (chamber extension) grants access to both pipe systems to allow inspection and flushing by conventional inspection equipment.

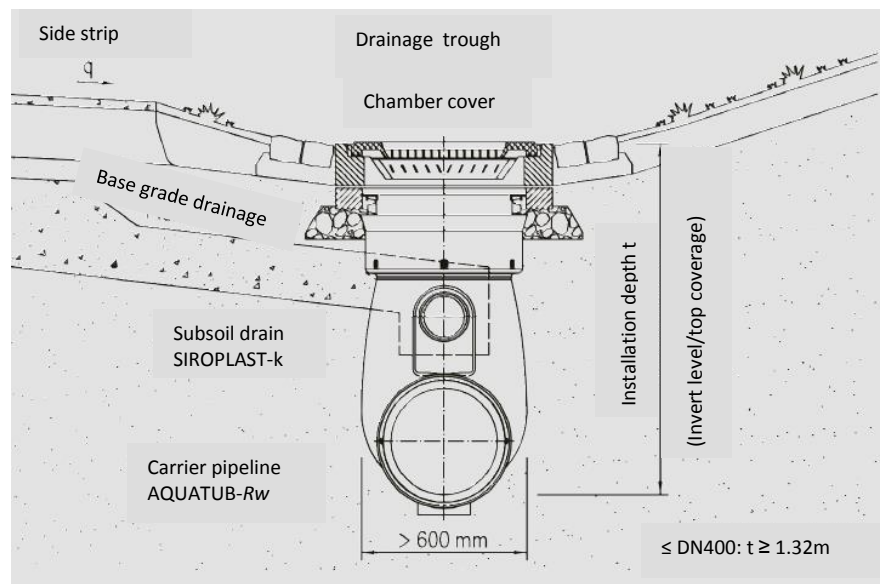

Example for use as inspection chamber of slender design in pickaback arrangement in road drainage with storm water sewer pipes AQUATUB-Rw and drainage pipes SIROPLAST-K

MULTI-*inspect* 600 DUO

- Inspection and flushing chamber for drainage and carrier pipelines in pickaback arrangement
- Particularly well suited in cramped site confines



Attention should be paid to the structural analysis and the manufacturer's installation instructions.

System Accessory MULTI-*inspect* 600 DUO

Important:

- If possible, MULTI-*inspect* 600 DUO chambers should be transported and stored on site in the original stillage. They should always be stored on an even and smooth surface.
- Continuous support at the given gradient must be provided in the pipe trench. The supporting layer of 10cm must consist of sand/gravel. Local depressions should be provided at joints so that the couplings do not initially rest on the support.
- Joints should be made using the recommended lubricant.
- Embedding has to be performed in accordance with EN 1610 with the use of bedding material that is suited for carrier and drainage pipelines.
- Chambers should be surrounded by a sand/gravel layer ($d \geq 20\text{cm}$). The bedding material should be compacted in layers.
- The MULTI-*inspect* 600 DUO chamber can be used with customary chamber covers to EN 124 (e.g. BEGU tops or 625 mm gratings).

The information given in this brochure is the most up-to-date available and is intended to provide information on our products and their possible applications. It is not a guarantee of certain features or of their suitability for certain specific applications. Our guarantee applies to compliance with our specifications, within the scope of our General Terms and Conditions. The current edition supersedes any former versions. Subject to change.

Chamber system and accessory

MULTI- <i>inspect</i> 600 DUO (pickaback arrangement)	Item No.
Chamber basic body of PE-HD, straight-way version with 2 outlets 180°, for connection of AQUATUB-Rw storm water sewer pipes up to DN400 and SIROPLAST-K drainage pipes DN150 in pickaback arrangement 2 outlets DN250 2 outlets DN300 2 outlets DN350 2 outlets DN400	7053330 7053320 7053310 7053300
Chamber basic body of PE-HD, starting/end version with 1 outlet, for connection of AQUATUB-Rw storm water sewer pipes up to DN400 and SIROPLAST-K drainage pipes DN150 in pickaback arrangement 1 outlet DN250 1 outlet DN300 1 outlet DN350 1 outlet DN400	7053332 7053322 7053312 7053302
Chamber basic body of PE-HD, with 2 outlets in offset design , for connection of AQUATUB-Rw storm water sewer pipes up to DN400 and SIROPLAST-K drainage pipes DN150 in pickaback arrangement 2 outlets DN250 2 outlets DN300 2 outlets DN350 2 outlets DN400	7053338 7053328 7053318 7053308
Chamber basic body of PE-HD, with 2 outlets and lateral inlet , for connection of AQUATUB-Rw storm water sewer pipes up to DN400 and SIROPLAST-K drainage pipes DN150 in pickaback arrangement project-specific	
Reducing connectors (from outlet DN400) for connection of AQUATUB-Rw storm water sewer pipes DN150 DN200 DN250 DN300 DN350	7058415 7058420 7058425 7058430 7058435
Profiled sealing ring for reducing connector (storm water sewer pipe)	7058401
Riser pipe (l = 100cm) (l = 300cm)	7057700 7057702
Profiled sealing ring for riser pipe	7057501
Coupling for riser pipe	7057500
SR end piece of system 625-500 followed by chamber cover (625mm) to EN 124)	7057502

Note: The system can be used with customary chamber covers (625mm) to EN 124.

HEGLER

Corrugated and Twin
Wall Pipes of Plastics

